



Chemical industry

Inline analytical technology for:

- concentration & density
- phase separation
- gas scrubbers & multi-component mixtures
- crystallization
- polymerization

Increase quality, save resources: LiquiSonic®.
With high-quality, innovative sensor technology.
Robust, precise, user-friendly.

LiquiSonic®

LiquiSonic® is an inline analytical system for determining the concentration in liquids directly in the production process. The analyzer is also used for phase separation and reaction monitoring. Sensor installation within the product stream means an extremely fast measurement that responds immediately to process changes.



User benefits include:

- optimal plant control through online and real-time information about process states
- maximized process efficiency
- increased product quality
- reduced lab costs
- immediate detection of process changes
- energy and material savings
- instant warning of interruptions in the process water or process liquid
- repeatable measuring results

LiquiSonic's® 'state-of-the-art' digital signal processing technology guarantees highly accurate, fail-safe measuring of absolute sonic velocities and liquid concentrations.

Integrated temperature detection, sophisticated sensor design, and know-how from SensoTech's extensive measurement history in numerous applications promises users a highly reliable, long-lived system.

Advantages of the measuring method are:

- absolute sonic velocity as a well-defined and retraceable physical quantity
- independent from conductivity, color or optical transparency of the process liquid
- installation directly into pipes, tanks or vessels
- robust, all-metal, gasket-free sensor design with no moving parts
- corrosion-resistant by using special material
- maintenance-free
- use in temperatures up to 200 °C (390 °F)
- accurate, drift-free measurements
- stable measurements even amid gas bubbles
- controller connection capacity reaching up to four sensors
- data transmission via fieldbus (Profibus DP, Modbus), analog outputs, serial interface or Ethernet

Inline process analysis

Inhalt

LiquiSonic®	2
Applications	4
Introduction	4
Phase separation	5
Concentration measurement in binary liquids	6
Chlorine-alkali electrolysis	7
Production of sulfuric acid	8
Monitoring of heat exchanger	9
Multi-component analysis	10
Gas scrubber	11
Reaction monitoring	12
Polymerization	12
Crystallization	12
LiquiSonic® System	14
LiquiSonic® 20 and 30	14
LiquiSonic® 40	15
Accessories	16
Fieldbus	16
Controller and field housing	16
UMTS router	16
Network integration	17
Quality and Support	18
SensoTech	19



Applications

Introduction

Controlling the process optimally and safely requires information provided promptly through a rugged and fast process analytical technology. Using the LiquiSonic[®] measuring technology and its easy integration into existing plant engineering systems at relatively low project costs enables partly significant improvements of the plant capacity, the process safety or product yields.

The LiquiSonic[®] systems are used in many fields of application particularly in the chemical industry:

- fast detection of transitions between product and carrier phases (LiquiSonic[®] 20 or 30)
- concentration measurements at different process steps related to quality and safety (LiquiSonic[®] 20 or 30)
- concentration measurement in complex mixtures of substances (multi-component analysis) to control procedural processes (LiquiSonic[®] 40)
- reaction monitoring of complex processes such as polymerization or crystallization to optimize yields, product quality and process safety (LiquiSonic[®] 30)

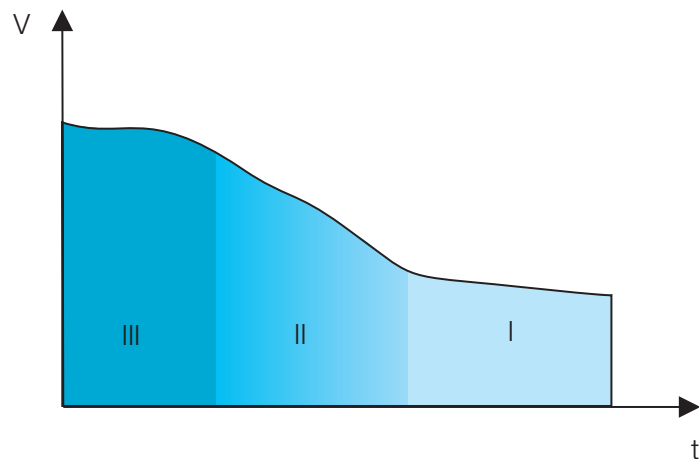
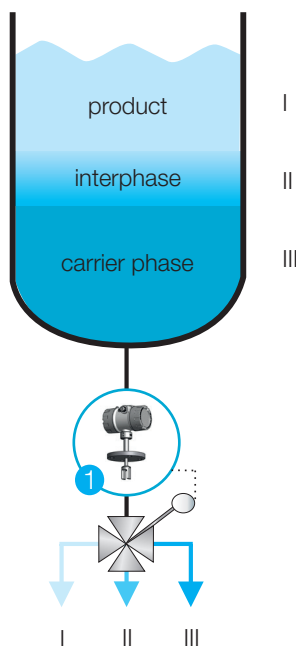

Phase separation in the batch process

Phase separation

Different product phases must be separated safely from carrier phases during many process engineering intermediate steps. This is done both in continuous and batch processes.

This is often done in batch processes by changing manually valves as well as by visual observation of phase transitions. Usually, sight glasses are used to observe the transitions visually. But this procedure is characterized by a low reproducibility. When using a LiquiSonic® immersion type sensor, the mentioned procedure is realized automatically.

The curve of the sonic velocity shows a typical and significant change of the signal between the individual phases. LiquiSonic® provides a clear signal to separate the product and carrier phase safe and reproducible. In particular, the very fast response time of the sensor within a few seconds enables a high selectivity that results with corresponding substance conversions immediately as remarkable product saving.

Similar to this is the application of LiquiSonic® in continuous phase separations. Here two sensors allow to control continuously the liquid feed and the phase flows to be separated in the settling tank. This enables an improved plant capacity connecting with increased product yields.

LiquiSonic® examples for application:

- silicone resin phases
- fatty alcohol phases in wastewater
- epoxy resin phases
- polyether phases
- gas-liquid phases

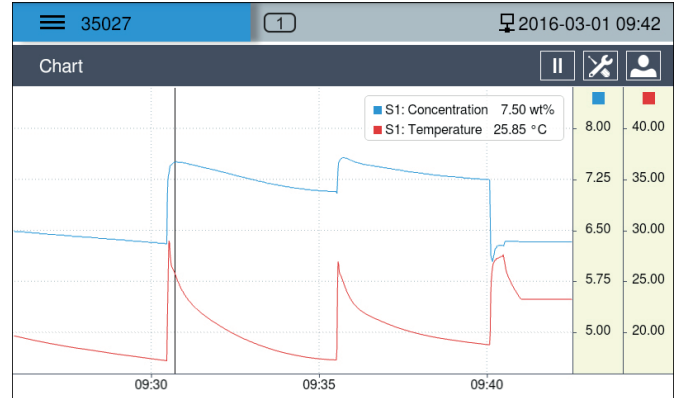

Trend view of the LiquiSonic® controller

Compared to conductivity sensors, the LiquiSonic® sensors can also be used in the most different separation processes from aqueous into organic phases or vice versa. The continuous measurement allows to regulate almost any separating ranges within the transition or slurry phases. The trend view of the controller shows directly the signal waveform. At the same time, it is possible to adjust thresholds for parameterization of digital controller outputs. For stand-alone solutions, these outputs can directly switch available diverter valves or valve clusters.

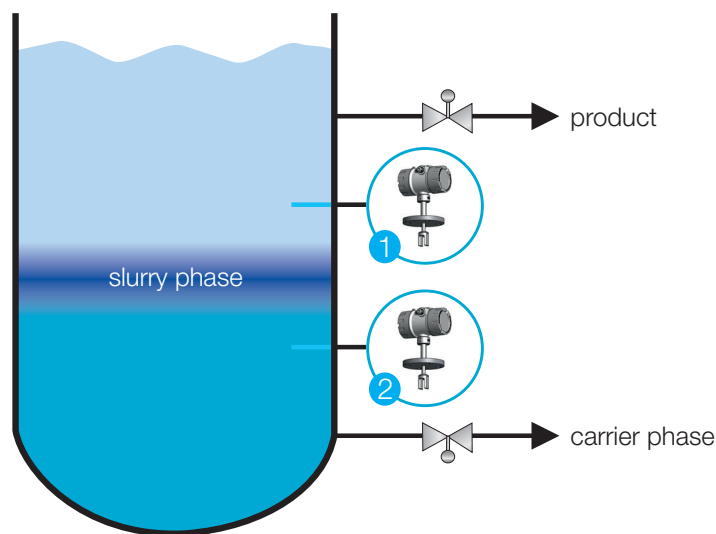

Phase separation in the continuous process

Concentration measurement in binary liquids

LiquiSonic® sensors provide clear and temperature compensated concentration values for different process liquids. The following tasks can be fulfilled at relevant steps of process for the concentration measurement:

- monitoring and identification of delivered products
- quality control at intermediate products
- control and monitoring (dilution, concentrating, product infiltration)
- monitoring the quality of the end product

LiquiSonic® systems provide excellent results, for example with the measurement of the following liquids:

acids	HCl, H ₂ SO ₄ , H ₃ PO ₄ , HNO ₃
bases	NaOH, KOH
inorganic substances	NaCl, KCl, ammonium sulfate
organic substances	ethanol, methanol, hexane
liquefied gas	propane, butane
suspensions	NaCl/H ₂ O, ammonium sulfate/H ₂ O

Relation between sonic velocity and concentration of binary liquids

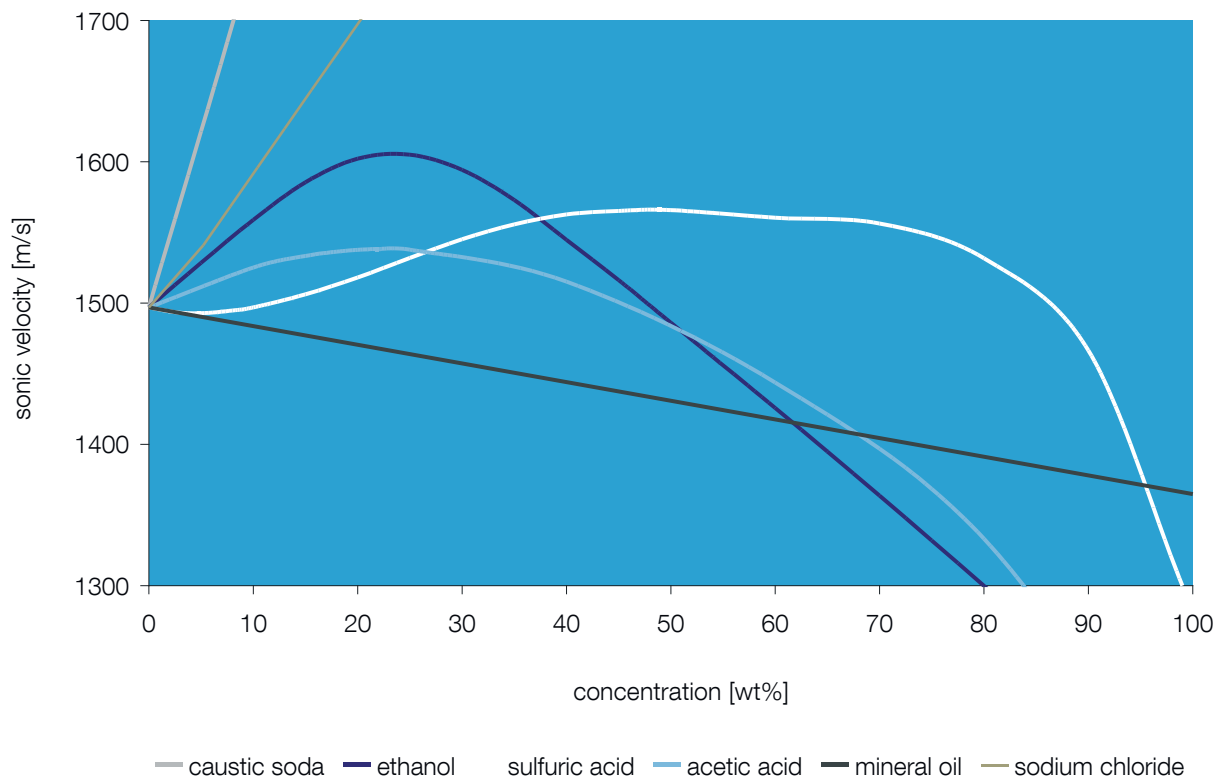

Chlorine-alkali electrolysis

Both chlorine (Cl_2) and caustic soda (NaOH) are one of the most important basic chemicals and produced from sodium chloride (NaCl). Chlorine can also be obtained from potassium chloride (KCl).

The chlorine-alkali process uses different electrolytic methods, but the most common types of production are the diaphragm, membrane or amalgam methods. The LiquiSonic® measuring technology is used in different methods and product flows to detect the concentration and to optimize the quality as well as productivity.

The measuring technology is also suitable for the salt production, for example for the brine extraction or dissolving plants, as well as in downstream processes, such as the chlor dehydrating with sulfuric acid (H_2SO_4) and the blending of caustic soda or hydrochloric acid (HCl).

Upon the strong demand of these basic chemicals, the large range of applications and the number of worldwide production locations, the LiquiSonic® systems have been used successfully for many years. Various measuring points are described in the following chart.

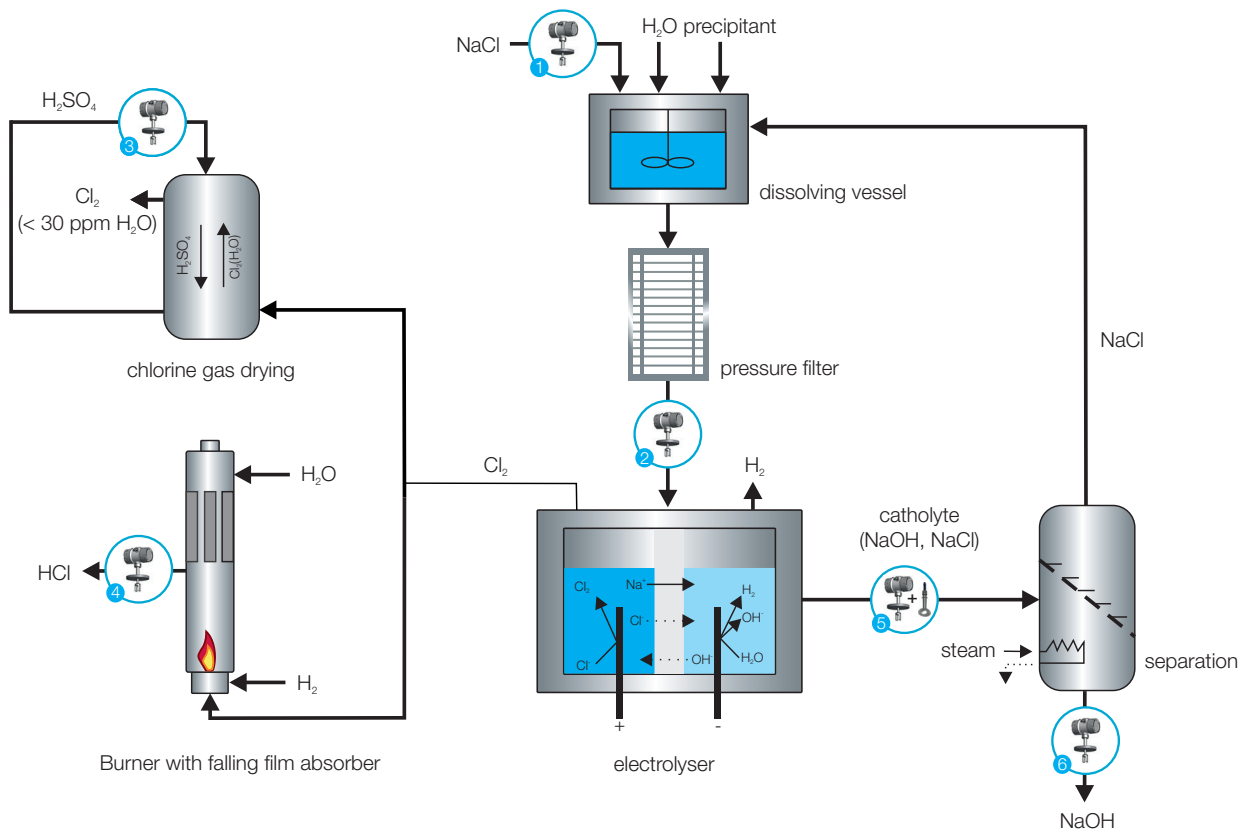

Chlorine-alkali process with concentration measurement of NaOH, H₂SO₄, NaCl and HCl

Measuring point	Installation	Measuring task
1, 2	pipe	monitoring of the incoming brine to the agreed target concentration, monitoring of the dissolving station to the maximum salt saturation
3	pipe	determination of the sulfuric acid concentration during the chlorine gas drying to avoid too strong dilution
4	pipe	determination of the desired final concentration of HCl
5	pipe	maximizing of the effectiveness degree of the electrolyzer through the determination of the catholyte concentration
6	pipe	determination of the required final concentration of NaOH

Production of sulfuric acid

Sulfuric acid is mostly produced with the contact process, in which elementary sulfur is converted to H_2SO_4 . This sulfur is formed again in great quantities during the flue gas desulfurization in the petrochemistry.

In the production process, the LiquiSonic® analyzers are used for the following measuring tasks:

- monitoring of the concentration in the SO_3 absorber to the oleum range
- monitoring and control of the blending to the required accepted concentration

LiquiSonic® does not only monitor the concentration of sulfuric acid during the production, but also for a number of further processes in different industries. These are, for example:

- syngas drying in the chemistry and petrochemistry
- etching agents in the steel industry
- ore digestion in the mining industry
- raw material for sulfate fertilizer
- basic chemical for diverse chemical products

The successful use of LiquiSonic® is not only based on the resistance to corrosion, lack of maintenance and the long lifetime, but also on the physical properties of sulfuric acid, as shown in the diagram below.

In comparison to the measurement with conductivity or density, the LiquiSonic® system generates a clear signal in the concentration range between 80 % and 100 % and provides unique process information at any time.

Advantage of sonic velocity over conductivity and density

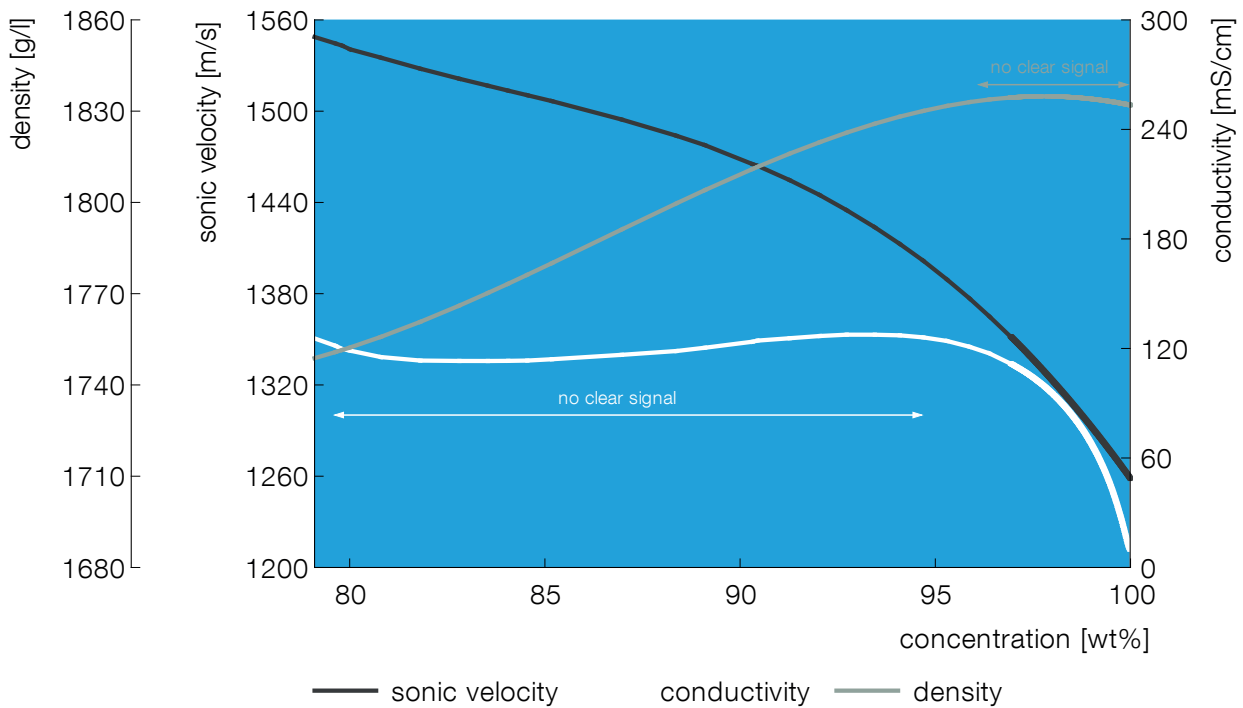

Monitoring of heat exchanger

Both shell-and-tube and plate heat exchangers are exposed to varied corrosion influences. In case of breakthroughs between the product and refrigerant cycle, critical process statuses or continuous plant shutdowns can occur, if suddenly process liquids enter in the refrigerant stream or vice versa. LiquiSonic® assures to detect these breakthroughs within seconds.

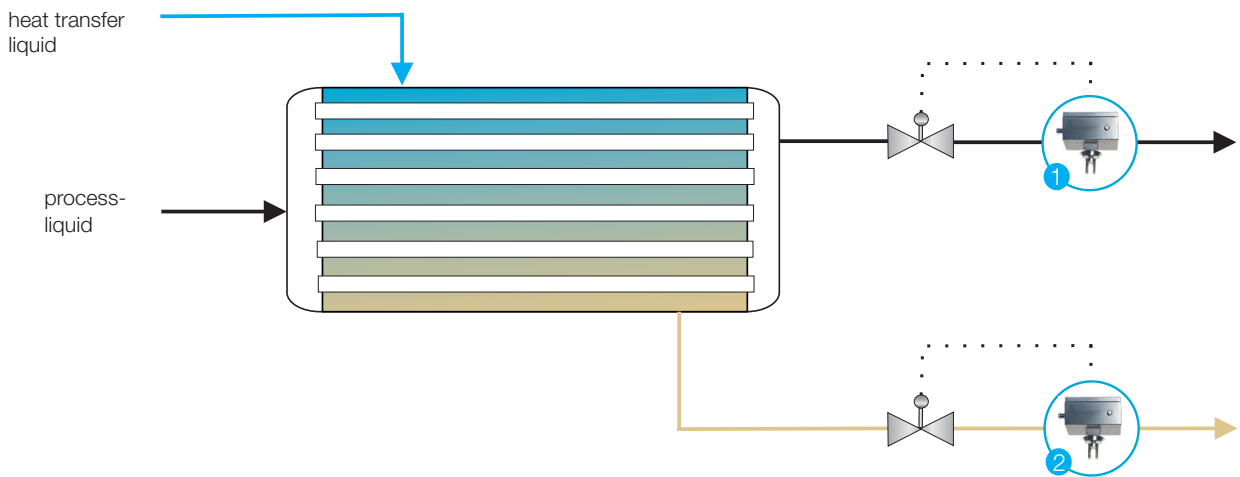

Monitoring of heat exchanger

Measuring point	Installation	Measuring task
1	pipe	detection of cooling water or break-in of refrigerant into the process liquid
2	pipe	detection of contaminations of the cooling water of refrigerant caused by process liquids

Multi-component analysis

A number of process liquids consists of three main components. Typical examples are:

- methanol-formaldehyde-water
- caustic soda-sodium chloride-water
- hydrochloric acid-iron-water
- caustic soda-propanol-water

The LiquiSonic® 40 system also determines the concentration of each component even in these mixtures of multi-component by using an additional physical quantity. Conductivity sensors are primarily used in this measurement.

At gas scrubbers and neutralization columns in particular, the continuous monitoring of the concentration of NaOH and NaCl is required for:

- reduction of using caustic soda by concentration controlled operation
- avoiding corrosion through unneutralized acid process liquid

Compared to the pH-value measurement, the monitoring of both concentrations provides extensive opportunities for process optimization and almost unlimited runtime. There are no cost-intensive efforts for calibration.

Examples:

- flue gas scrubber
- gas drying
- phosgene absorber
- sulfur dioxide scrubber
- benfield scrubber
- ammonia facilities
- synthesis gas facilities
- natural gas facilities
- chlorine gas scrubber

Concentrations c_1 and c_2 at constant temperature

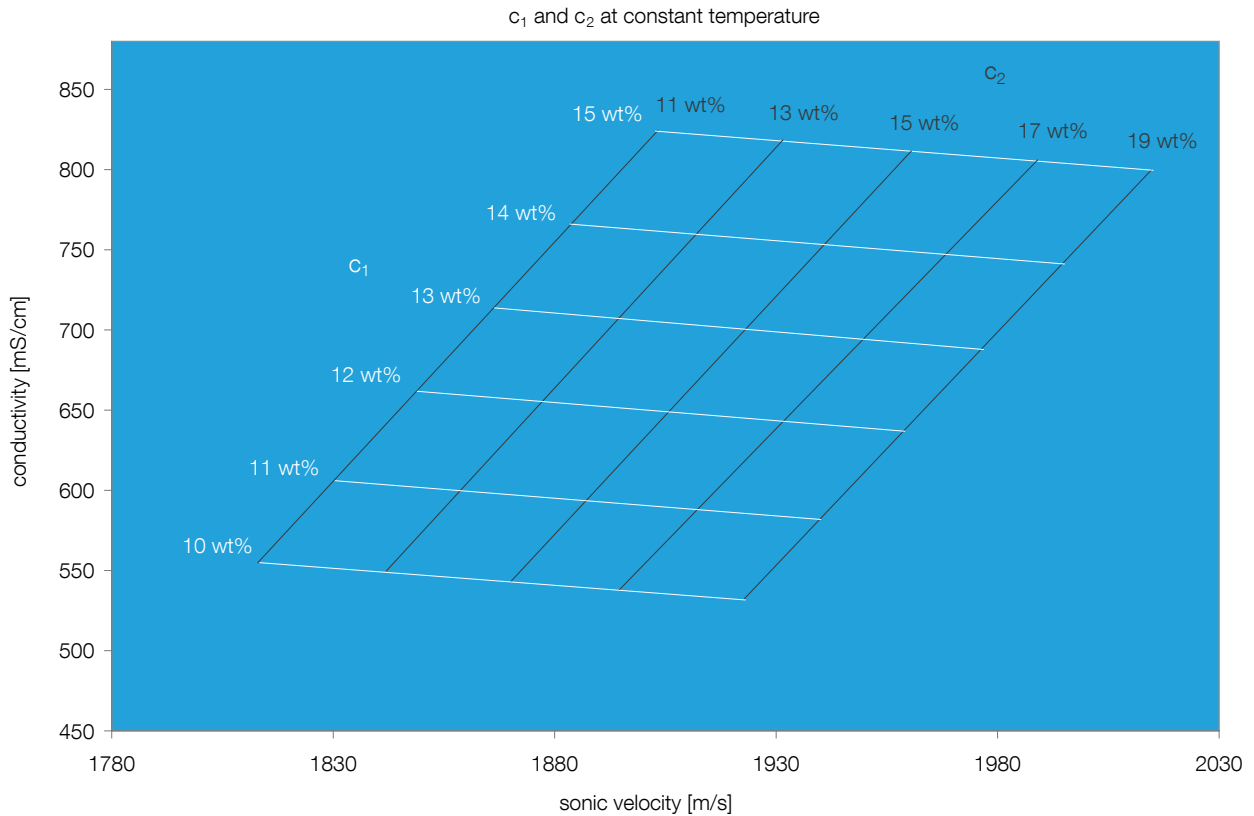

Gas scrubber

The LiquiSonic® 40 systems are used with success at different measuring points for the process analysis in gas scrubbers. The LiquiSonic® system facilitates separate inline determination of the concentration of the scrubbing solution and salt without any time delay.

Hence, it is possible to sharpen the scrubbing liquid in a defined manner and to keep the liquid concentration always in the range of maximum solubility and absorption. Therefore underdosing, i.e. insufficient scrubbing, is avoided as well as overdosing, i.e. excessive input of materials and related costs.

Example: emergency vent scrubber

The scrubbing liquid of an emergency vent scrubber circulates and is continually in contact with the gas stream to be cleaned. If toxic or environmentally hazardous chemicals are included in this stream, they will be absorbed. Even during standard operation (without emergency), certain components, e.g. CO₂, are chemically bound and the NaOH concentration decreases. In order to ensure an effective absorption in the event of an emergency and a sufficient volume of scrubbing liquid, the concentration of NaOH and salts (NaCl and Na₂CO₃) must be monitored.

If the NaOH content is under limit, it must be redosed. In case of too high salt content, the salt must be removed from the circulation stream, to prevent crystallization in the system and blocked nozzles. The LiquiSonic® analyzer allows the concentration measurement of 3-components-liquids, due to the parallel detection of two physical quantities such as sonic velocity and conductivity.

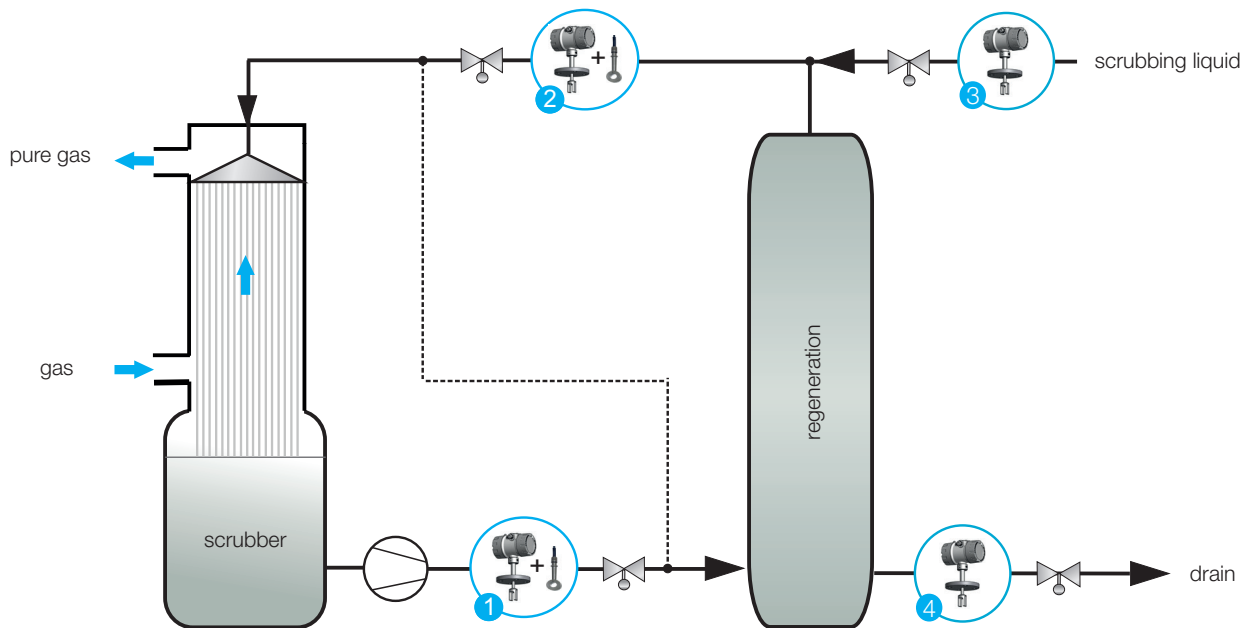

Gas absorption process in a jet scrubber

Measuring point	Installation	Measuring task
1, 2	pipe	concentration monitoring of the scrubbing liquid and salt
3	pipe	concentration monitoring of the of fresh scrubbing liquid
4	pipe	break-in monitoring during the treatment of salts

Reaction monitoring

The LiquiSonic® measuring device facilitates monitoring and control of various reactions, in particular in the batch process. Depending on the process and liquid, catalytic and enzymatic reactions, such as polymerization, crystallization as well as mixing processes can be optimized to ensure the quality of the final product.

Product	Sonic velocity
styrene	1354 m/s
polystyrene	2330 m/s
vinyl chloride	897 m/s
polyvinyl chloride	2260 m/s

Polymerization

In monomer and polymer systems in general, the differences of sonic velocity between monomer and polymer are determined primarily by chain length and the degree of branching and crosslinking.

The table shows clearly, that these differences in sonic velocity between monomer and polymer and also between start and end of polymerization reactions are very large.

The sonic velocity and concentration are directly linked to each other. Furthermore, the degree of polymerization determining the polymer content in the monomer correlates with the concentration. Using the LiquiSonic® measuring technology, it is possible to determine the concentration and the degree of polymerization.

Crystallization

The sonic velocity measurement enables to determine the nucleation and saturation point and, thus, the metastable range.

Sonic velocity and temperature are measured during cooling and heating of the solution to establish the relevant parameters within the process. The sonic velocity presented as a function of the temperature, important crystallization parameter, such as saturation and nucleation temperature, as well as the position in the metastable range can be directly determined.

During the crystallization, it is possible to measure the difference to the saturation (degree of saturation), the degree of supersaturation or the crystal content and to determine it as a control variable for influencing the crystallization.

Concentration as a function of temperature within a crystallization process

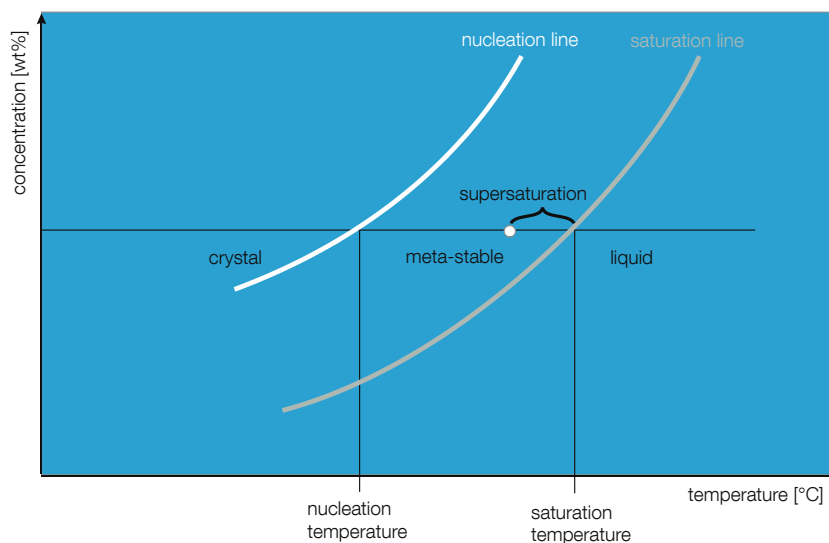



In liquids, we set the measure.

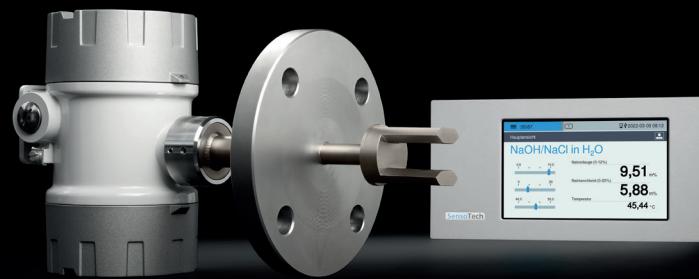

LiquiSonic® System

LiquiSonic® 20 and 30

The LiquiSonic® system consists of one or more sensors and one controller.

The ultrasonic sensor has the actual ultrasonic measuring path and the highly precise temperature detection.

The controller 30 is a highly efficient device which includes up to four sensors. They can be installed in different steps with a standard maximum distance of 1,000 m between controller and sensor. As option, higher distances are possible.

The controller 20 is a variant with a reduced scope of functions and only to one sensor connectable.

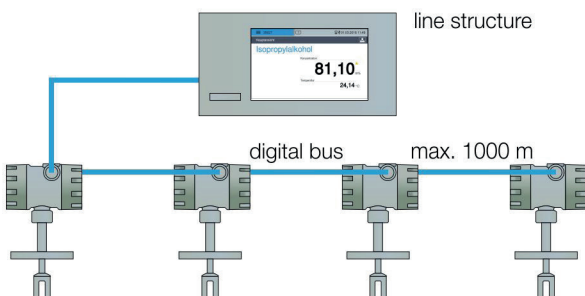

Controller with connection of maximum four sensors

Each sensor works autonomous and can be used in different applications. The liquid-wetted parts of the sensor are made of stainless steel DIN 1.4571 as standard. The rugged, completely enclosed design requires no gaskets or "window", making it totally maintenance-free.

Additional sensor features such as flow / stop or full / empty pipe monitoring greatly advance process control. The LiquiSonic® high-power technology stabilizes measuring results, even when facing gas-bubble accumulations or large-scale signal attenuation through the process flow.

The special sensor electronics are integrated in a closed die-cast housing with a protection degree of IP65. If necessary, the electronics housing can be mounted apart from the sensor.

For use in hazardous areas, the immersion sensor Ex 40-40 is approved by ATEX and IECEx certification (Ex d IIC T1 to T6 Ga/Gb, zone 0 / zone 1) and FM certification (Class I, Division 1, Groups A, B, C, DT1-T6).

The controller 30 processes and displays the measuring results. The operation via the high resolution touch screen is easy and intuitive. Secure network integration including web server allow operating the controller alternatively via a browser with a PC or tablet.

The process data is updated every second. The displayed value can be adjusted to internal reference values. If the measuring values exceed or fall below the threshold, the display shows an alarm message and a signal will be sent immediately.

The data can be transmitted in several defined analog or digital forms or through different fieldbus interfaces to communicate with process control systems or computers.

The controller features an integrated data logger which can store up to 2 GB of process information with up to 32 (optional 99) data sets for different process liquids. For processing on the PC, the data can be transferred via network or USB port. In addition, the controller enables easily creating process reports for documentation purposes.

The event log records states and configurations such as manual product switches, alarm messages or system states.

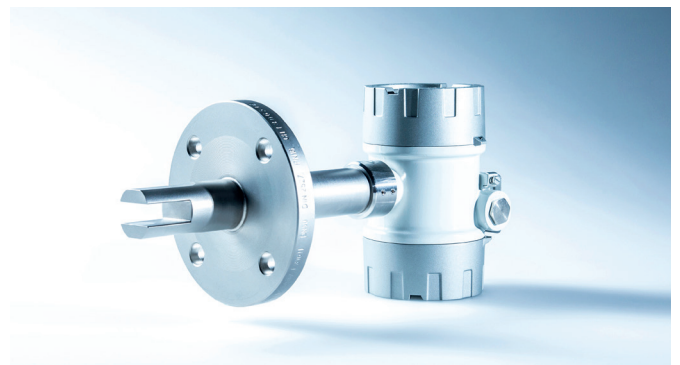

Immersion sensor Ex 40-40

LiquiSonic® 40

The LiquiSonic® 40 analyzer enables the determination of concentration in 3-component liquids. For example, in neutralization processes it is possible to determine separately the concentration of the scrubbing solution and the salt.

The measuring principle is based on the fact that concentration changes of individual components of a liquid affect physical quantities like sonic velocity, conductivity or density. This characteristic is stored as calculation mode in the evaluation unit (controller) to convert the physical variables in concentration values.

With the parallel detection of two physical variables (sonic velocity and conductivity), it is possible to determine two concentrations at the same time.

The measuring values are available for the user or process control system over analog outputs as well as fieldbus.

For the application in aggressive liquids, the standard LiquiSonic® 40 is equipped with a Halar (also known as E-CTFE) coated flange sensor and a PFA or PEEK coated conductivity sensor, which are chemically resistant to a number of substances.

The flange sensor has a highly efficient ultrasonic ceramic to ensure the measurement even at high portion of gas in the liquid. For the application in hazardous areas, the flange sensor has an ATEX and IECEx approval (II 1/2 G / Ex d IIB T1 to T6 Ga/Gb).



LiquiSonic® controller and Halar coated flange sensor

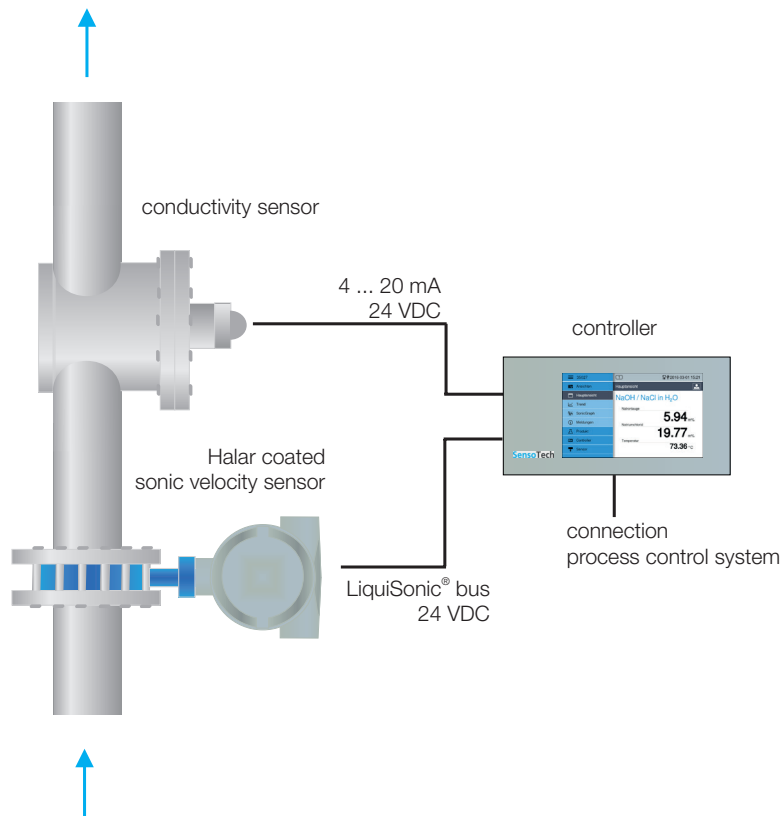

LiquiSonic® 40 measuring point

Accessories

There are several possibilities to install the LiquiSonic® analyzer appropriately and to facilitate the integration into the process control system. The following products have proved to be useful.



Controller housing 19" 4 HU

Controller and field housing

The controller is designed for rack-mounted systems. It is alternatively available with a 19" housing 4 HU.

In order to be able to mount the controller into the field, two variants of field housings made of plastic or stainless steel can be delivered, which meet on-site conditions in an optimal way.

- material: anodized aluminum
- dimensions: 482.9 (19") x 177 (4 HU) mm
- application: rack-mounted system

Fieldbus

The fieldbus option provides the possibility to integrate the controller in a PCS or to automate the process flow via PLC. Beside the transfer of measuring values like concentration and temperature it is also possible to exchange parameters and control data (for example product switch).

The controller supports different fieldbus systems and follows the standards recommended by the respective standards organizations. Common variants are Modbus and Profibus DP.

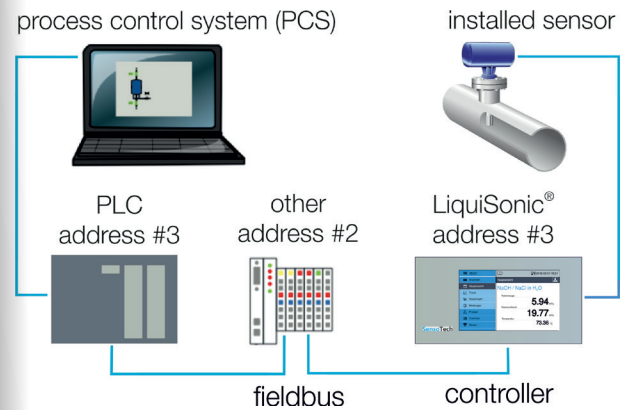

Connection interfaces

UMTS router

With a UMTS router it is possible to operate the LiquiSonic® controller remotely. For this purpose, the controller is connected to the UMTS router and appropriate IP address must be entered in the browser on the PC.

The remote connection includes the following features:

- uploading new product data sets on the controller
- reading out the controller data storage, e.g. to record product data for unknown liquids
- monitoring and configuration of the controller and sensors
- worldwide and fast customer support by Sensotech service



Network integration

The LiquiSonic® controller has an Ethernet interface, that makes the integration into the corporate network possible. After entering the user name and password, the access to the stored logs is possible.

Integrating the controller into the network enables remote control, view of status information, transfer of product data sets or calibration of products.

The Network integration includes

- web server (HTTP),
- command line (TELNET),
- file transfer (FTP),
- time synchronisation (NTP),
- e-mail notification (SMTP).



Quality and Support

Enthusiasm for technical progress is the driving force behind our company as we seek to shape the market of tomorrow. As our customer you are at the center of all our efforts and we are committed to serving you with maximum efficiency.

We work closely with you to develop innovative solutions for your measurement challenges and individual system requirements. The growing complexity of application-specific requirements means it is essential to have an understanding of the relationships and interactions involved.

Creative research is another pillar of our company. The specialists in our research and development team provide valuable new ways to optimize product attributes, such as testing new types of sensor designs and materials or the sophisticated functionality of electronics, hardware and software components.

Our SensoTech quality management also only accepts the best production performance. We have been certified according to ISO 9001 since 1995. All device components pass various tests in different stages of production. The systems have all gone through an internal burn-in procedure. Our maxim: maximum functionality, resilience and safety.

This is only possible due to our employee's efforts and quality awareness. Their expert knowledge and motivation form the basis of our success. Together we strive to reach a level of excellence that is second to none, with passion and conviction in our work.

Customer care is very important to us and is based on partnerships and trust built up over time. As our systems are maintenance free, we can concentrate on providing a good service to you and support you with professional advice, in-house installation and customer training.

Within the concept stage we analyze the conditions of your situation on site and carry out test measurements where required. Our measuring systems are able to achieve high levels of precision and reliability even under the most difficult conditions. We remain at your service even after installation and can quickly respond to any queries thanks to remote access options adapted to your needs.

In the course of our international collaboration we have built up a globally networked team for our customers in order to provide advice and support in different countries. We value effective knowledge and qualification management. Our numerous international representatives in the important geographical markets of the world are able to refer to the expert knowledge within the company and constantly update their own knowledge by taking part in application and practice-oriented advanced training programs.

Customer proximity around the globe: an important element of our success worldwide, along with our broad industry experience.



In liquids, we set the measure.
With innovative sensor technology.
Tough, accurate, user-friendly.

SensoTech

SensoTech is a provider of systems for the analysis and optimization of process liquids. Since our establishment in 1990, we have developed into a leading supplier of process analyzers for the inline measurement of liquid concentration and density. Our analytical systems set benchmarks that are used globally.

Manufactured in Germany, the main principle of our innovative systems is to measure ultrasonic velocity in continuous processes.

We have perfected this method into an extremely precise and remarkably user-friendly sensor technology. Beyond the measurement of concentration and density, typical applications include phase interface detection or the monitoring of complex reactions such as polymerization and crystallization.

Our LiquiSonic® measuring and analysis systems ensure optimal product quality and maximum plant safety. Thanks to their enhancing of efficient use of resources they also help to reduce costs and are deployed in a wide variety of industries such as chemical and pharmaceutical, steel, food technology, machinery and plant engineering, car manufacturing and more.

It is our goal to ensure that you maximize the potential of your manufacturing facilities at all times. SensoTech systems provide highly accurate and repeatable measuring results even under difficult process conditions. Inline analysis eliminates safety-critical manual sampling, offering real-time input to your automated system. Multi-parameter adjustment with high-performance configuration tools helps you react quickly and easily to process fluctuations.

We provide excellent and proven technology to help improve your production processes, and we take a sophisticated and often novel approach to finding solutions. In your industry, for your applications – no matter how specific the requirements are. When it comes to process analysis, we set the standards.





SensoTech GmbH
Steinfeldstraße 1
39179 Magdeburg-Barleben
Deutschland
+49 39203 514 100
info@sensotech.com
www.sensotech.com

SensoTech Inc.
69 Montgomery Street, Unit 13218
Jersey City, NJ 07303
USA
+1 973 832 4575
sales-usa@sensotech.com
www.sensotech.com

SensoTech (Shanghai) Co., Ltd.
Room 609, Bldg.1, No.778, Jingji Road.
Pilot Free Trade Zone, 201206 Shanghai
China
+86 21 6485 5861
sales-china@sensotech.com
www.sensotechchina.com



LSM183_01_14